

AVK RivetNut Tools

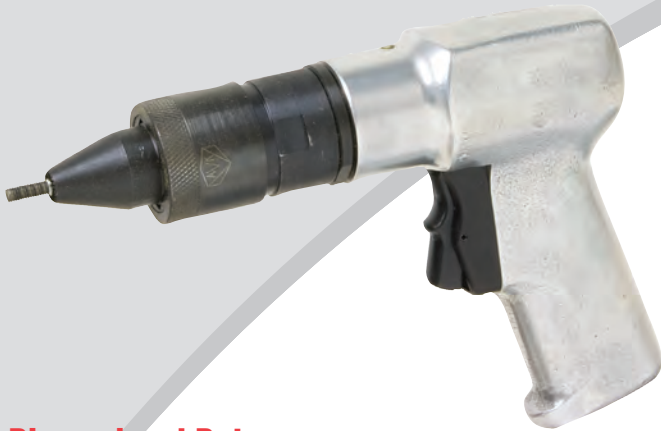

The tool shown on this page has been specifically designed to install the A-L, A-K, A-H, A-P and A-O series Inserts.

Select the type of insert (not shown) and thread size required for your application, then select the appropriate RPM tool from the charts below.

Dimensional Data

RPM	Weight (lbs)	A	B	C	D (Dia)	E (Dia)	F (Dia Max)	G
3000	2.55	1.86"	4.75"	7.75"	1.57"	1.00"	0.400"	1.3"
1500	2.58	1.86"	4.75"	7.75"	1.57"	1.00"	0.400"	1.3"
900	3.18	1.86"	6.00"	9.00"	1.57"	1.00"	0.500"	1.3"
600	3.18	1.86"	6.00"	9.00"	1.57"	1.00"	0.640"	1.3"
350	3.25	1.86"	5.37"	8.37"	1.50"	1.42"	0.900"	NA

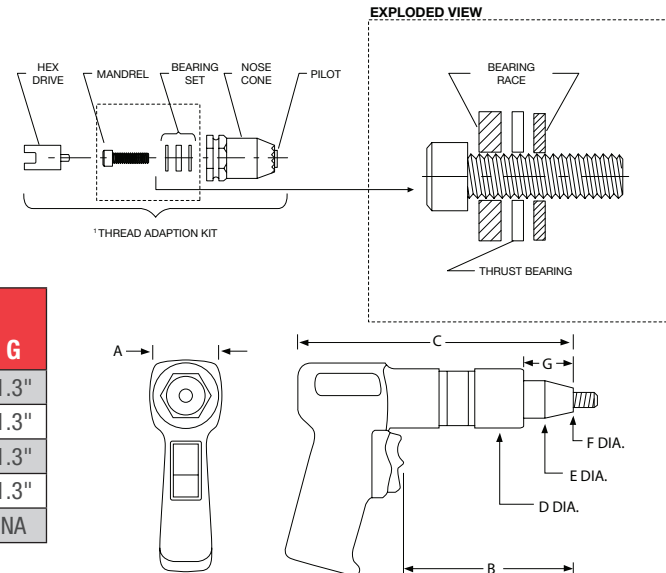

PROPER AIR SUPPLY SET-UP REQUIRES:

- Refer to tool selection chart below for proper PSI setting at 25 CFM
- Inline oiler / separator
- Air pressure gauge
- 5/16" minimum hose ID
- 5/16" minimum fittings ID

PREVENTATIVE MAINTENANCE REQUIREMENTS:

- The bearing set must be kept in a WET lubricated condition to ensure proper tool operation. AVK suggests the use of high temperature grease such as LUBRIPLATE BRAND 930 AA.
- The tool mandrel should be inspected for thread wear or damage and replaced. AVK suggests the use of Unbrako or Holo-Krome socket head cap screws.

SPECIAL FEATURE—This tool's nose cone design incorporates a special pilot / serrated tip that is essential to proper insert installation. The "AK" prefix in the tool part number designates this feature.

Tool Selection

Model (Complete Tool)	Thread Size	RPM	¹ Thread Adaption Kit	PSI (Dynamic)
AKPT30P632	6-32 UNC	3000	AKPT632TAK	70-80
AKPT30P832	8-32 UNC	3000	AKPT832TAK	75-90
AKPT15P1024	10-24 UNC	1500	AKPT1024TAK	60-80
AKPT15P1032	10-32 UNF	1500	AKPT1032TAK	60-80
AKPT15L1032	10-32 UNF	1500	AKPT1032TAK	60-80
AKPT9P420	1/4"-20 UNC	900	AKPT420TAK	70-90
AKPT6P518	5/16"-18 UNC	600	AKPT518TAK	80-110
AKPT6P616	3/8"-16 UNC	600	AKPT616TAK	80-110
AKPT3P813	1/2"-13 UNC	350	AKPT813CTA	80-110
AKPT30P470	M4x0.7 ISO	3000	AKPT470TAK	70-80
AKPT15P580	M5x0.8 ISO	1500	AKPT580TAK	60-80
AKPT9P610	M6x1.0 ISO	900	AKPT610TAK	70-90
AKPT6P8125	M8x1.25 ISO	600	AKPT8125TAK	80-110
AKPT6P1015	M10x1.5 ISO	600	AKPT1015TAK	80-110
AKPT3P12175	M12x1.75 ISO	350	AKPT12175CTA	80-110

Spare Parts

Hex Drive	² Mandrel (10 Per Bag)	Bearing Set	Nose Cone
29NPT22	B3SH632-1500	32PT1	77AKPT6
29NPT23	B3SH832-1500	32PT2	77AKPT8
29NPT4	B3SH1024-1750	32PT4	77AKPT10
29NPT4	B3SH1032-1750	32PT4	77AKPT10
29NPT5	B3SH420-1500	32PT5	77AKPT250
29NPT6	B3SH518-2225	32PT7	77AKPT3125
29NPT7	B3SH616-2225	32PT8	77AKPT375
29NPT26	B3SH813-2500	30NPT500	77AKPT500
29NPT24	B3SH470-40	32PT3	77AKPT470
29NPT10	B3SH580-45	32PT4	77AKPT580
29NPT11	B3SH610-40	32PT6	77AKPT610
29NPT12	B3SH8125-55	32PT7	77AKPT8125
29NPT25	B3SH1015-55	32PT10	77AKPT1015
29NPT27	B3SH12175-60	30NPT500	77AKPTM12

² Special Order Only

Note: UNF Fine Threads are Available